

Innovative Construction

Equipment Rental Catalog



Cleveland:

1-800-362-9267

Toledo:

1-800-860-3352

Canton:

1-877-258-7601

chasehipps.com





Phipps helps contractors put work in place correctly and profitably by renting, selling, and servicing specialized equipment for concrete placing, finishing, surface preparation, climate control and demolition, as well as pumps used to apply construction sealants and coatings.

Innovative Construction Product Solutions Since 1921.

- **Quality Products**
 - **Technical Expertise**
 - **Trusted Service**

Floor Prep Equipment

National 5700 Battery Riding Floor Scraper	4
National 7700 Battery Riding Floor Scraper	4
National 8000 Propane Riding Floor Scraper	4
Bartell Propane T2200 Pro Riding Floor Scraper	4
National 550 Floor Scraper	5
8" Shot Blaster	5
National 6280 HD Self Propelled Scraper	5
BlastPro 10" Riding Shotblaster	5
Husqvarna PG 510	6
Husqvarna PG 820 Grinder.....	6
Husqvarna PG 530 Grinder.....	6
Diteq 18" TG-18 Propane Floor Grinder	6
Husqvarna PG 280 Grinder.....	7
Husqvarna PG 450 Grinder	7
CDC Larue 7" Stand-up Grinder	7
Gorilla Concrete EG-7 7" Edge Grinder.....	7
Gorilla 4.5" Dustless Crack Chaser.....	8
Stand-Up Joint Clean-Out Saw.....	8
24" Propane Powered Burnisher	8
Dewalt DWV012 10 Gallon HEPA Vacuum	8
Bolt 20" Floor Buffer/Scrubber.....	8
Hand Grinder w/ Dust Shroud - 4", 5", 7"	8
Pullman Holt Wet Pump-Out Vac.....	9
Husqvarna S 26 HEPA Vacuum	9
Husqvarna S 36 220V HEPA Vacuum.....	9
Husqvarna DC 3300 Vacuum.....	9
Husqvarna T8600 Propane or Electric.....	9
Husqvarna C3000 Pre-Separator	9
Smith 15" Propane Powered Scarifier FS351LP.....	10
Smith 10" Gas Powered Scarifier SPS10.....	10
Bartell (Electric) Scarifier SP8-E	10
Smith 10" Electric Scarifier	10
Husqvarna Diamond Grinding Segments... ..	11

Concrete Related Equipment

Allen HDX600 8'	12
Allen HDX605 8'	12
MQ STXD6i 10'	12
Allen MSP 470.....	12
MQ HHXD5 8'	12
Bartell TS78 6'	12
Bartell Titan 96 8'	12
Allen MSP 445 8'	12
Allen Pro 436 Walk Behind Trowel.....	13
Allen Pro 446 Walk Behind Trowel.....	13
MQ 24" Walk Behind Edging Trowel	13
16 cuft Concrete Buggy	13
Canycm SC75 Pivot Dump Buggy	13
Power Pusher Electric Wheel Barrow	13

Collomix LevMix Mixer	14
Whiteman 7 cuft Mortar Mixer.....	14
Husqvarna BV 30 Power Sced.....	14
Electric Breaker	14
Mix-N-Go Concrete Mixer	14
Rotary Demo Hammer Drill	14
Minnich A-1-Series	15
Minnich A 2C.....	15
Husqvarna LF80 LAT	15
Husqvarna LF100 LAT.....	15
Vibratory Rammer	15
Backpack Vibrator	15
Handheld Vibrator	15
Allen Roller Tube Finisher	15

Cutting & Demolition Equipment

Husqvarna Electric Cut-N-Break Saw.....	16
Husqvarna Gas Cut-N-Break Saw	16
Husqvarna K 4000.....	16
Husqvarna 6500 Prime Power Cutter.....	16
Husqvarna K 770 Concrete Saw.....	16
Husqvarna PP65 High Frequency Power Pack	16
Husqvarna K 770 VAC Saw w/ Dust Control.....	16
Husqvarna DXR 140 & DXR 300 Demolition Robots	17
Grappler.....	17
Cutting Shears.....	17
Breaker.....	17
Standard Bucket.....	17
Drum Cutter.....	17
Sherpa 100 ECO	18
Grapple Bucket.....	18
Pallet Forks	18
Hydraulic Hammer	18
Vacuum System.....	18
EcoVolve ED800, ED1000, ED1500.....	18
Husqvarna Soff-Cut Prowler 150 Saw	20
Husqvarna 1000 Soff Vac.....	20
Husqvarna Soff-Cut 2000 Saw.....	20
Husqvarna Soff-Cut 4000 Saw.....	20
Husqvarna Soff-Cut 4200.....	20
Husqvarna FS7000 D 36" Diesel Saw.....	21
Husqvarna FS3500 Saw Gas or Electric.....	21
Husqvarna FS400 18" Saw	21
Gorilla 10" Electric Walk Behind Saw	21
7"- 9" Spider Walk Behind Concrete Saw.....	21

Pumps/Sprayers

Chemgrout Trailer Mounted Pump & Mixer	22
QuikSpray Carrousel Pump Electric or Air	22

Graco S340E Electric Powered Pump/Sprayer	22
Graco 833 Gas Powered Big Rig Sprayer	22
Graco 7900 Gas-Powered Sprayer.....	22
Kenrich Air Operated Pump	23
Seal Boss Dual Component Polyurea Pump.....	23
Seal-Boss 1:1 Injection Pump	23
Seal-Boss 2:1 Injection Pump	23
Ultra-Trak 36" Pressurized Application System	23
32" Concrete Cleaner.....	23
Bartell S201 Power Sprayer.....	23
4000 PSI Pressure Washer	23

Air & Climate Control

Powerheat 4500 Trailer.....	26
Quest Power Air Mover A3000 Plus.....	26
Quest PowerDry 4000 Pro	26
Husqvarna A 1200 Air Scrubber.....	26
KwiKool KIB1411	26
KwiKool KPO5-21	26

Blasting Equipment

Graco Eco-Quip 400T.....	27
Graco Eco-Quip EQS	27
Graco Eco-Quip EQM	27

Miscellaneous Items

Arbortech Brick and Mortar Saw	28
Husqvarna Hand Held Core Drill.....	28
Fein MultiMaster Tool.....	28
5" Grinder with Tuckpointing Shroud.....	28
MAX Tool Rebar TwinTier RB441T.....	28
Spectra HV101 Laser Kit.....	28
Bartell 5000W Generator	29
Generac 17KW Generator.....	29
Generac MMG75D Generator	29
32" Concrete Cleaner.....	29
Allen Steel Pans.....	30
Soff Cut Early Entry Blades	30
Husqvarna Diamond Cup Wheels.....	30
Husqvarna HI Series Diamond Blade	31
Vari-Cut 14" Blade	31
Husqvarna VH Series Diamond Blade.....	31
Husqvarna FR3 Fire Rescue Blade	31
Husqvarna Professional F600C Series.....	31
Finish Blades.....	31
Combo Blades	31
Clip-On Float Blades	31

Cleveland: (800) 362-9267

Canton: (877) 258-7601 • **Toledo:** (800) 860-3352

www.chasehipps.com

FLOOR PREP EQUIPMENT



National 5700 Battery Riding Floor Scraper

\$720/Day \$2160/Week \$6480/Month

The All Day Battery Ride-On removal and floor preparation machine - this machine has the ability to operate through an average eight hour day without requiring a battery recharge, or electrical cord assistance.

Specifications

Width*	24-1/2"
Height	50-1/2"
Length*	58-1/2"
Weight	2244 lb
Removable Weight	185 lb front
Weight (machine only)	2059 lb
Speed	up to 120 ft/min
Voltage	115/230
Frequency	60 Hz/ 50 Hz
HP	4

* Note: These measurements are without tooling attached.



National 7700 Battery Riding Floor Scraper

\$820/Day \$2460/Week \$7380/Month

Powered by 12 200-amp hour batteries that exceed the industry standard, this machine is everything you need it to be. Bigger, heavier, and faster than the 5700, it is designed to remove difficult material and built to operate on almost any jobsite.

Specifications

Width*	30"
Height	51"
Length*	58-1/2"
Weight	2572 lb
Removable Weight	185 lb front
Weight (machine only)	2572 lb
Speed	up to 200 ft/min
Voltage	115/230
Frequency	60 Hz/ 50 Hz
HP	4

* Note: These measurements are without tooling attached.



National 8000 Propane Riding Floor Scraper

\$820/Day \$2460/Week \$7380/Month

The propane powered 8000 omits the lowest emissions in its class while designed to achieve massive removal rates. Easy to transport, fits in a standard door frame and accessible to most passenger and freight elevators, the 7600 can go places the others can not.

Specifications

Width*	30"
Height	61"
Length*	63"
Weight**	2887
Removable Weight	1003 lb front, 75 lb rear
Weight (machine only)**	1809
Speed	up to 200 ft/min
HP	25

* Note: These measurements are without tooling attached.



Bartell Propane T2200 Pro Riding Floor Scraper

\$820/Day \$2460/Week \$7380/Month

The workhorse in floor removal technology, the 55HP Terminator T-2200PRO is designed to meet the needs of the most demanding removal project. The newly updated T-2200PRO is the most advanced flooring removal machine on the market.

Specifications

Width	27.5"
Height	62"
Length	54.5"
Weight	2310 lbs
Working Width	26"
Production	up to 3500 sq ft/hour
HP	55 LPG Engine



National 550 Floor Scraper
 \$115/Day \$345/Week \$1035/Month

Perfect for residential and light commercial use, the 550 has removal capability of some it's larger more expensive competitors.

Specifications

Width	17-3/4"
Max. Height with handle	42-1/2"
Height without handle	21"
Max. Length	32-1/2"
Weight	123 lb
Removable Weight	44 lb
Weight (machine only)	79 lb
Speed	Manual
Max Cord Length	50 ft
Voltage	115/230
Frequency	60 Hz/ 50Hz
HP	1
Amps	15



8" Shot Blaster
 \$285/Day \$855/Week \$2565/Month

Perfect for smaller jobs such as residential garage floors, pool decks, and small industrial floors, this 8" shot blaster runs on single phase common power.

Specifications

Width	12"
Blasting Width	8"
Height	41"
Length	41"
Weight	240 lb
Blasting Capacity	Up to 350 sq ft/hr (110v)
Max Cord Length	50 ft
Voltage	110V (12 amp)
HP	3HP



National 6280 HD Self Propelled Scraper
 \$250/Day \$750/Week \$2250/Month

This self-propelled stripper will remove the worst of today's glued-down floors, gummy commercial carpet, VCT, solid vinyl, radial rubber tile, sheet rubber, indoor and outdoor sport surfaces, roofing material, etc.

Specifications

Width	17-3/4"
Max. Height	46"
Min. Height (handle folded)	30"
Max. Length (handle extended)	51"
Min. Length (handle folded)	29"
Weight	425 lb
Removable Weight	47 lb front / 43 lb side
Weight (machine only)	335 lb
Production	10-45 ft/min
Max Cord Length	50 ft
Voltage	115/230
Frequency	60 Hz/ 50 Hz
HP	1.5
Amps	20

* Note: These measurements are without tooling attached.



BlastPro 10" Riding Shotblaster
 \$985/Day \$2955/Week \$8865/Month

The BP-10-27 ride on self-contained shot blasting system is the perfect solution for medium to large jobs and eliminates the need of a generator or electric power.

Specifications

Production Capacity	1,500 sq. ft. /hr.
Blast Pattern	10"
Travel Speed	0-200 ft. /min.
Blast Motor	27 HP Kohler.
Fuel	Propane
Dimensions	78"x34"x57"
Weight	1,525 lbs.



FLOOR PREP EQUIPMENT



Husqvarna PG 820 RC Grinder

\$515/Day \$1545/Week \$4635/Month

With 32 in. wide grinding width PG 820 is our most productive concrete floor grinder suitable for industrial applications. PG 820 is one of the market's most powerful and efficient machines. Excellent choice for concrete floor preparation and repair as well as all polishing and grinding applications – both wet and dry. Comes with 1-set of Prep Diamonds & PCD Blades. Any additional tooling must be purchased by the customer. Vac not included.

Specifications

Power output	17 hp
Rated current, A	32 A
Voltage	380 / 480 V
Grinding width	32 "
Grinding disc	10.5 "
Grinding pressure total	737 lbs
Recommended Generator Size (w/o vac)	25kW
Recommended Generator Size (w/ vac)	45kW
Recommended Vac Rental	Husqvarna T8600 or DC 6000



Husqvarna PG 530 Grinder

\$425/Day \$1275/Week \$3825/Month

The PG 530 is a concrete floor grinder that is excellent for residential and light commercial purposes. Excellent choice for concrete floor preparation and repair as well as all polishing and grinding applications – both wet and dry. Comes with 1-set of Prep Diamonds & PCD Blades. Any additional tooling must be purchased by the customer. Vac not included.

Specifications

Power Output	5 hp
Rated Current, A	16 A
Voltage	220/240 V
Grinding Width	21"
Grinding Disc	9.5"
Grinding Pressure total	295 lbs
Weight	475 lbs
Recommended Generator Size (w/o vac)	15kW
Recommended Generator Size (w/ vac)	25kW
Recommended Vac Rental	Husqvarna DC 3300

6



Husqvarna PG 510

\$375/Day \$1125/Week \$3375/Month

The PG 510 is a planetary floor grinder with three grinding discs and a total grinding width of 515 mm. It is suitable for removing coatings, grinding and polishing concrete.

Specifications

Power Output	3-5.4 HP
Rated Current A	15
Voltage	220V
Grinder Width	20"
Grinding Disc	3" x 9"
Grinding Pressure Total	145-176 lbs
Weight	265-293 lbs
Recommended Generator Size (w/o vac)	12 kW
Recommended Generator Size (w/vac)	15 kW
Recommended Vac Rental	Husqvarna DC3300



Diteq 18" TG-18 Propane Floor Grinder

\$325/Day \$975/Week \$2925/Month

The TG-18 is a true multi-function piece of equipment, able to tackle a broad range of surface-prep and finishing applications.

Specifications

Power Output	18hp
Disc Width	18"
Dimensions (LxWxH)	56"x 25"x 37"
Weight	360 lbs

Note: Pricing on all grinders includes 30 grit diamond segments and PCD's



Husqvarna PG 450 Grinder
 \$305/Day \$915/Week \$2745/Month

PG 450 is a versatile and user-friendly planetary floor grinder. Perfect for a wide range of applications, e.g. coating removal, concrete grinding and concrete polishing. 50' of cord. Comes with 1-set of Prep Diamonds & PCD Blades. Any additional tooling must be purchased by the customer. Vac not included.

Specifications	
Grinding width	17.7"
Grinding disc	7.1"
Grinding pressure total	152.1 lbs
Weight	240.3 lbs
Voltage	115V
Amps	20
Recommended Vac Rental	Husqvarna S26 or S36 Vac



Husqvarna PG 280 Grinder
 \$225/Day \$675/Week \$2025/Month

11" Floor grinder for surface preparation and grinding of adhesive residue, paint and spackle on medium-sized concrete areas. 50' of cord. Comes with 1-set of Prep Diamonds & PCD Blades. Any additional tooling must be purchased by the customer. Vac not included.

Specifications	
Grinding disc	11"
Grinding pressure total	77 lbs
Recommended Vac Rental	Husqvarna S26 or S36 Vac

Dimensions	
Weight	154 lbs
Voltage	115V
Amps	20



Gorilla Concrete EG-7 7" Edge Grinder
 \$105/Day \$315/Week \$945/Month

Ideal for detail work on larger slabs, the EG-7 allows you to easily grind tight edges and corners without hand-grinding. Hug walls or seams by moving the grinder head to either side, or keep it in the middle for use as a regular small grinder. It also features excellent dust-control.

Specifications	
Power Requirements	2hp, 12/240 volts
Weight	70 lbs
Cup Wheel	4.5"-7"
Arbor Size	5/8"
Min Vacuum Requirements	256 CFM
Max Cord Length	30ft



CDC Larue 7" Stand-up Grinder
 \$90/Day \$270/Week \$810/Month

Hum-B floor grinder covers more square feet in less time with less effort, maximizing comfort and increasing productivity. The ergonomically designed floor surfacing equipment allows the user to grind in an upright position, reducing fatigue, backaches, and job site injuries. Diamond cup wheel included. Any additional tooling must be purchased by the customer. Vac not included.

Specifications	
Weight	62 lb
Max Cord Length	30ft

FLOOR PREP EQUIPMENT



Gorilla 4.5" Dustless Crack Chaser

\$95/Day \$285/Week \$855/Month

This 4.5" dustless grinder will increase productivity and keep you off your knees. 2" vacuum port adapter. Rental includes 4.5" crack chasing blade. Weight 32 lbs.



24" Propane Powered Burnisher

\$150/Day \$450/Week \$1350/Month

A propane powered, ultra-high speed burnisher that gives floor care professionals the options they want to customize a machine to their needs. Burnishing Pad sold separately.

Specifications

Width	29"
Height	39"
Length	50"
Empty Weight	220 lb
Weight	250 lb



Bolt 20" Floor Buffer/Scrubber

\$50/Day \$150/Week \$450/Month

Our Bolt dual-speed floor machines are high quality, durable machines offering power and versatility for scrubbing and stripping. It features an adjustable handle height to accommodate various user heights. Five inch non-marking wheels allow for easy transportation. Pads purchased separately.

Specifications

Motor	1.75 HP, 115V 175/300 RPM - Dual Speed
Pad Speed	175/300 RPM
Electrical System	115V, 60 Hz
Switches	Dual Levers with safety lock
Wheels	Two 5" wheels with non-marking tread
Dimensions: (L x W x H)	24.5" X 21" X 47"



Stand-Up Joint Clean-Out Saw

\$125/Day \$375/Week \$1125/Month

This US Saws SX13550 Dust Buggy Joint Cleanout Concrete Saw can be used directly with the Metabo W24-230 grinder to help you maintain a clean jobsite. The SX13550 can be used with a 7" or 8" blade to reach a maximum cutting depth of 2".



Dewalt DWV012 10 Gallon HEPA Vacuum

\$40/Day \$120/Week \$360/Month

Lightweight for easy transporting and heavy duty for jobsite durability. Powerful 15 Amp Motor to deliver maximum suction and automatic filter cleaning every 30 seconds without stopping. Dust collection bags sold separately.

Specifications

Air Flow Capacity (CFM)	150
Voltage	110v
Current (Amps)	15
Weight	33 lbs
Inlet	1.25"



Hand Grinder w/ Dust Shroud - 4", 5", 7"

\$50/Day \$150/Week \$450/Month

Hand grinder with dust shroud. Perfect for small areas and edging. Comes with diamond cup wheel.



Pullman Holt Pump-out Vac
 \$85/Day \$255/Week \$765/Month

The 45-20 POV Wet vacuum, specially designed for high volume pick-up of slurries, spills, water damage projects and flood water. Equipped with a 40 gallons per minute discharge pump built-in inside a 20 gallon tank.

Specifications

Motor (HP)	2HP
Weight	80lbs
Pump (W)	550
Cord Length	25 ft



Husqvarna S 36 220V HEPA Vacuum
 \$160/Day \$480/Week \$1440/Month

S 36 is a very powerful single-phase HEPA dust extractor to match the grinding machines Husqvarna PG 530 (1-phase), PG 450, PG 400 and PG 280 as well as small to midsize scarifiers, grinders, shot blasters and handheld power tools.

Specifications

Air Flow Capacity (CFM)	353
Water Lift (in)	100
Voltage	220
Current (Amps)	14.9
Weight	140
Inlet	2"



Husqvarna S 26 HEPA Vacuum
 \$85/Day \$255/Week \$765/Month

This professional dust extractor is suitable for building, grinding, plaster and concrete dust. Equipped with two tested and certified HEPA H13 filters. Features include Jet Pulse pre-filter cleaning, hour counter and vacuum meter for filter control.

Specifications

Air Flow Capacity (CFM)	258
Water Lift (in)	100
Voltage	120
Current (Amps)	19.6
Weight	127
Inlet	2"



Husqvarna C3000 Pre-Separator
 \$85/Day \$255/Week \$765/Month

Using a pre-separator enhances the dust extractor's capacity to handle material that would normally be considered difficult to manage such as soot, burning particles, liquids and light material in large quantities.

Specifications

Capacity	10 gallon
Weight	49 lbs



Husqvarna DC 3300 Vacuum
 \$160/Day \$480/Week \$1440/Month

A 1-phase dust collector for wet and dry applications. It has the suction capacity and filtration technology for the toughest jobs, effectively and efficiently eliminating airborne dust. Recommended for Husqvarna PG 530 1-phase.

Specifications

Air Flow Capacity (CFM)	325
Voltage	220v
Current (Amps)	16
Weight	214
Inlet	3"



Husqvarna T8600 Propane or Electric
 \$205/Day \$615/Week \$1845/Month

Designed for large-scale projects that demand substantial dust extraction.

Specifications	Propane	Electric
Power	18HP (14kW)	11.5HP
Power Supply	Kawasaki, Propane	3-phase
Air Flow (CFM)	410	353
Water Life, in	115	110
Inlet	3"	3"
Weight	628	454

FLOOR PREP EQUIPMENT



Smith 15" Propane Powered Scarifier FS351LP
 \$475/Day \$1425/Week \$4275/Month

Lockable depth-control settings for consistent removal in the "impact zone," up to 2x faster removal speeds with adaptable changes for diamond shaving, rototrans or carbide scarifying, re-designed vacuum pickup location to contain debris.

Specifications	
Power (Propane)	25HP
Removal	Up to 15" wide, 3/8" depth/pass
Speed	Up to 700 sf/hr (approx.)
Weight	650 lbs



Smith 10" Gas Powered Scarifier SPS10
 \$395/Day \$1185/Week \$3555/Month

The SPS10 is available with the most cutter tools and accessories to tackle every type of surface preparation and removal job on asphalt, concrete, steel or wood surfaces.

Specifications	
Power(Gas)	11HP Honda
Removal	Up to 10" wide, 1/4" depth/pass
Speed	Up to 500 sf/hr (approx.)
Weight	250 lbs



Bartell (Electric) Scarifier SP8-E
 \$305/Day \$915/Week \$2745/Month

For any surface, for any coating, the SP8 performs with great versatility. It offers high speed, accurate surface preparation at an economical price.

Specifications	
Model	SP8-E
Engine	Various 3hp Motors
Standard Cutting Width	<8" (203 mm)
Depth (per pass)	<1/16" (1.6 mm)
Weight	150lbs (68kg)
Voltage	220V
Cord Length	50ft



Smith 10" Electric Scarifier
 \$395/Day \$1185/Week \$3555/Month

The SMITH SPS10™ is the world's most reliable electric powered scarifier on the market. Made in the USA by SMITH Manufacturing, the leading manufacturer of cutters and removal equipment, the SPS10 is #1 choice for the professional looking to remove-it faster, with better surface finishes.

Specifications	
Engine*/Motor	5hp Electric 230 Volt Single Phase
Weight (including drum)	250 lbs.
Cutting Width	10"
Cutting Depth/Pass	Up to 1/4"
Speed	Up to 500 sf/hr (approx.)
Cord Length	50ft

ICRI Surface Profile Guideline

Proper surface prep is an extremely important step in the application of new floor coatings, liquid, tile or otherwise. All Industrial coating manufacturers specifically call out for detailed surface prep in their specifications for their coating systems. The International Concrete Repair Institute (ICRI) has created a Concrete Surface Profile (CSP) chart for all manufactures and contractors to follow.

Diamond Grinding

ICRI Profiles: 2 & 3

Diamond Grinding can produce a ICRI CSP of between 2 & 3.

A number 2 is normally produced via grinding with diamond tooling of 30 grit.

Shot Blasting

ICRI Profiles: 3 - 7

Shot blasting is capable of producing ICRI CSP profiles of between 3 - 7 typically

Scarification

ICRI Profiles: 5 - 9

Scarifiers are capable of producing ICRI CSP Profiles between 5 - 9

Husqvarna Diamond Grinding Segments

Whatever level of finish you are looking for, we have tools developed for most materials – from the hardest concrete floor to the most porous for grinding and polishing of old and new concrete floors.

Redi Lock diamond tool hardness scale



For more information, see page 10

Application guide – removal.

MATERIAL	1400 SERIES					600 SERIES			200	PCD	ARROW
	G 1410	G 1420	G 1440	G 1470	G 1480	G 620	G 640	G 670	G 200		
POROUS CERAMIC GLUES	-	-	●●●	●●●	●●●	●	-	●●●	-	●●●	-
PLASTIC-LIKE CERAMIC GLUES	-	-	●●●	-	-	●	-	-	-	●●●	●●●
VINYL GLUES*	●	●●	●●●	●	●	●●	●●●	●	●●●	-	●●●
PAINT AND THIN EPOXY (<2 MM)	-	●●	●●●	●	●	●●	●●●	●	●●●	-	●●●
THICK EPOXY (15-40 MM)	-	●	●●●	●	-	●●	●●●	●	●●●	●●●	-

●●● = Optimal ●● = Good ● = Acceptable - = Not recommended

Application guide – grinding.

MATERIAL	1400 SERIES					600 SERIES			200	PCD	RT CAP CUTTERS
	G 1410	G 1420	G 1440	G 1470	G 1480	G 620	G 640	G 670	G 200		
RAIN-DAMAGED CONCRETE	-	-	-	●●	●●●	-	●	●●	●	●	-
CONCRETE, SOFT	-	-	-	●●●	●●●	-	●●	●●●	●●●	●	-
CONCRETE, MEDIUM HARD	-	●	●●●	●●●	-	●	●●●	●●●	●●●	-	●●
CONCRETE, HARD	●●●	●●●	●	-	-	●●●	●	-	●	-	●●●
SEMI-POLISHED CONCRETE	●●●	●	-	-	-	●	-	-	-	-	●●●

●●● = Optimal ●● = Good ● = Acceptable - = Not recommended

CONCRETE RELATED EQUIPMENT



Fully Hydraulic Riding Trowels			
	Allen HDX600 8'	Allen HDX605 8'	MQ STXD6i 10'
Pricing	\$525/Day \$1575/Week \$4725/Month	\$525/Day \$1575/Week \$4725/Month	\$540/Day \$1620/Week \$4860/Month
Panning Width	100"	101.5"	117"
Dimensions (LxWxH)	108"x 55.5"x 56"	108.4"x 52.2"x 61.4"	125"x 65"x 56"
Max. Rotor Speed	160 RPM	160 RPM	130 RPM
Weight	1613 lbs.	2050 lbs.	2270 lbs.
Engine	44 HP Turbo Charged Kubota Diesel	57 HP Kubota WB1605 Gasoline	55 HP John Deere Turbo Diesel
Fuel Capacity	11 gal.	13 gal.	11 gal.
Rotors - # of Blades	46" - 5	46" - 5	- 6



Power-Steering Riding Trowels		
	Allen MSP 470	MQ HXD5 8'
Pricing	\$415/Day \$1245/Week \$3735/Month	\$415/Day \$1245/Week \$3150/Month
Panning Width	95"	91"
Dimensions (LxWxH)	101"x 50"x 59"	98"x 50"x 54"
Max. Rotor Speed	180 RPM	170 RPM
Weight	1450 lbs.	1440 lbs.
Engine	44 HP Turbo Charged Kubota Diesel	Vanguard DM950DT Turbo Diesel
Fuel Capacity	6 gal.	9 gal.
Rotors - # of Blades	46" - 5	- 5

12



Mechanical Riding Trowels			
	Bartell TS78 6'	Bartell Titan 96 8'	Allen MSP 445 8'
Pricing	\$275/Day \$825/Week \$2475/Month	\$350/Day \$1050/Week \$3150/Month	\$350/Day \$1050/Week \$3150/Month
Panning Width			97.5"
Dimensions (LxWxH)	78"x 41"x 52"	96"x 48"x 46"	101.5"x 50.5"x 59.5"
Max Rotor Speed			165 RPM
Weight	620 lbs.	904 lbs.	1052 lbs.
Engine	22 hp Kohler CH740/CH740 Gasoline	Vanguard 37 HP Gasoline	Kohler CH1000, 6 gal. (999 cc) Gasoline
Float Blade Size	10"x 14"	10"x 18"	
Finish Trowel Size	6"x 14"	6"x 18"	
Combination Trowel Size	8"x 14"	8"x 18"	
Rotors - # of Blades	- 4	- 4	46" - 5



Note: Trowel blades purchased separately



Allen Pro 436 Walk Behind Trowel
 \$95/Day 285/Week \$855/Month

Engineered for the concrete professional, our Allen Walkers are designed to produce high tolerance concrete floors (as measured by F-Numbers) with high quality features that are hard to find on other trowels.

Specifications

Engine	HONDA GX160
Dimensions (L X H)	70" X 38"
Rotor Diameter	36" - 4- BLADES
Maximum Rotor Speed	118 RPM
Weight	198 LBS



Allen Pro 446 Walk Behind Trowel
 \$95/Day \$285/Week \$855/Month

Engineered for the concrete professional, our Allen Walkers are designed to produce high tolerance concrete floors (as measured by F-Numbers) with high quality features that are hard to find on other trowels.

Specifications

Engine	Honda™ GX270 (270 cc)
Dimensions (L x H)	89 in x 39 in
Rotor Diameter	46 in 4-blades
Maximum Rotor Speed	180 RPM
Weight	252 lbs
Trowel Arms & Spider	Standard Duty



MQ 24" Walk Behind Edging Trowel
 \$95/Day \$285/Week \$855/Month

This compact design is ideal for finishing edges and around risers, has a powerful Honda GX 120 engine.

Specifications

Engine	Honda GX 120 3.5 HP
Rotor Diameter	24"
Rotor Speed	0-130 RPM
Weight	170 lbs



Canycom SC75 Pivot Dump Buggy
 \$200/Day \$600/Week \$1800/Month

The Pivot Dump SC75 rubber track concrete buggy delivers maximum performance in any environment including wet or muddy conditions, rough, uneven terrain and loose sand and gravel. It can hold up to 16 cubic feet of material. A 22-hp engine enables the machine to reach speeds up to 6 mph. Features include hydrostatic drive; rubber tracks, a 90-degree dump angle and 180-degree pivoting dump.

Specifications

LxWxH	95" x 35" x 57"
Payload	1655 lbs - 16 Cuft
Engine	22hp Robin
Speed	0-6 MPH
Weight	1410 lbs



16 cuft Concrete Buggy
 \$125/Day \$375/Week \$1125/Month

The Whiteman WBH-16 Series power buggy has earned a reputation as the most durable and dependable design on the market. Heavy-duty frame with low center of gravity for increased stability and traction. Capacity of 16-cubic feet. Powered by a Honda GX390 engine with recoil start. Large 5.5-gallon fuel tank for extended service.

Specifications

Travel Speed	7.25 mph
Weight	1135 lbs - 1300lbs



Power Pusher Electric Wheel Barrow
 \$125/Day \$375/Week \$1125/Month

Designed to transport heavy loads with ease and eliminate the ergonomic challenges and unnecessary production halts associated with traditional wheelbarrow solutions for improved operator productivity and safety.

Specifications

Liquid Volume	5 Cubic Feet
Solid Volume	9 Cubic Feet
Capacity	750 lbs
Width	32"
Height	38-1/2"
Length	69"
Speed	4 mph
Electrical	24v Dc
Run Time	6-8 hrs full charge, 3-4 hrs under load

CONCRETE RELATED EQUIPMENT



Collomix LevMix Mixer

Blending of leveling compounds fast and easy with the new Collomix LevMix mobile mixer. The LevMix unites three steps in one operation: mixing, transporting and pouring out. Save time and mix up to three bags of mixing material at once.

Specifications

Mixing Volume	15 gal. / 3 sacks
Max.Load	220 lbs
Mixing Bucket	17 gallons bucket - tall
Power Rating	1600 watts
Speed	660 rpm (no load) 410 rpm (under load)
Weight	empty 93 lbs.
Dimensions	27.2 x 20.5 x 46.9 inches



Whiteman 7 cuft Mortar Mixer

\$95/Day \$285/Week \$855/Month

Mixes up to 7 cubic feet (340 liters), 3-1/2 - 4 bags of material. Heavy duty safety grate with built-in bag cutter. Durable paddle shaft of 1-1/4" square hardened steel. Double sealed bearings with eight spring-loaded grease-able seals. Gas or electric available.

Specifications

Drive System	V-belt
Drum Capacity	7 cu. ft 3 1/2 - 4 bags
Dump Type	Manual
Discharge Height	21 in, 530 mm
Drum Type	Steel
Drum Thickness	10
Engine Cover Thickness	14
Tire Size	B78x13
Frame Type	Tubular
Paint Type	Powder coat
Power Rating	220V single phase

14

Mix-N-Go Concrete Mixer

\$70/Day \$210/Week \$630/Month

Multiquip's Mix-N-Go's now come with the convenience of a thick polyethylene drum. Perfect for small footings, bases, patching. Use as a wheelbarrow or with a stand. Drum Capacity (Mixing) 3 Cuft.

Specifications

Max Drum Capacity (Mixing)	3 cu. ft
Drum Type	Poly
Power Source	1.0 HP, 115V, 60 Hz single phase Electric Motor
Overall Length	48.75 in 1238 mm
Overall Width	23.5 in 597 mm
Overall Height	56.1 in 1425 mm
Shipping Dimensions	48.5 x 26.63 x 56.1 in 1232 x 600 x 864 mm
Operating Weight	138 lb 62.6 kg
Shipping Weight	138 lb 62.6 kg



Electric Breaker

\$105/Day \$315/Week \$945/Month

Specifications

Weight	75lbs
--------	-------

Husqvarna BV 30 Power Screenshot

\$30/Day \$90/Week \$360/Month

BV 30 is a versatile, petrol-driven walk-behind concrete power screed designed to deliver a high-quality slab. It is equipped with a twin de-vibrated and foldable handle, which can be adjusted for comfort and maneuverability. Offered with 10', 12', and 14' screed blades.



Rotary Demo Hammer Drill

\$85/Day \$255/Week \$765/Month

These innovative drilling and chiseling hammers save money because they lose no time due to maintenance and failures. Comes with brushing bit and chisel bit. For use with SDS-Max bits. Drill bits sold separately.



Minnich A-1-Series
 \$170/Day \$510/Week \$1530/Month

Specifications	
Usage	On-Grade
Drill Bit Diameter	.625" - 2.50"
Max Drill Depth	18"
Min Cutout Width	48"
SCFM Required	185
Weight	200 lbs
Includes Dust Collection System	



Minnich A 2C
 \$260/Day \$780/Week \$2340/Month

Specifications	
Usage	On-Slab
Drill Bit Diameter	.625" - 2.50"
Max Drill Depth	18"
Min Cutout Width	48"
SCFM Required	375
Weight	900 lbs
Includes Dust Collection System	



Husqvarna LF80 LAT
 \$105/Day \$315/Week \$945/Month

LF 80 LAT is a lightweight, fast-operating forward plate compactor, designed for efficient compaction of soil and asphalt. It is ideal for repair jobs and maintenance work, such as driveways and parking lots. The large water tank features an oversized cap to enable less frequent and faster refills. It is easy to clean, leaves no marks on the pavement and uses whatever water is available on-site.

Specifications	
Operating weight	181 lbs
Centrifugal Force	4361 lbf
Speed	108 ft/min
H/A vibration, low vibration handle	1.2 m/s ²
Plate width	16.5"
Plate Length	22.4"



Vibratory Rammer
 \$90/Day \$270/Week \$810/Month

Specifications	
Percussion Rate Max.	687 blows/min
Weight	130lbs
Impact force	3,597 lbf
Engine	2-cycle gasoline



Backpack Vibrator
 \$65/Day \$195/Week \$585/Month



Handheld Vibrator
 \$60/Day \$180/Week \$540/Month



Husqvarna LF100 LAT
 \$125/Day \$375/Week \$1125/Month

The LF 100 LAT is a fast-operating forward plate compactor, designed for efficient compaction of asphalt and soil. It is ideal for repair jobs and maintenance work, such as driveways and parking lots.

Specifications	
Operating Weight	236 lbs
Centrifugal Force	3754
Speed	82 ft/min
H/A Vibration, low vibration handle	1.2 m/s ²
Plate Width	19.7"
Plate Length	23.4"



Allen Roller Tube Finisher
 \$250/Day \$750/Week \$2250/Month

Strikes off concrete fast and accurately. Perfect quick strike finisher for paving - especially for pervious concrete applications. Comes with choice of tube size - 6', 8', 14', 16', 18' and 26'.

Specifications	
Weight	220 lbs



CUTTING & DEMOLITION EQUIPMENT



Husqvarna Electric Cut-N-Break Saw

\$110/Day \$330/Week \$990/Month

Cut-n-Break method is the natural choice when you need to cut deep but want a machine with low tool and maintenance costs. The K 3000 Cut-N-Break enables you to cut as deep as 16" from one side.

Specifications

Blade Diameter	9"
Max Cutting Depth	16"
Rated Current, Amps	15A
Electric Motor Volts	120v



Husqvarna Gas Cut-N-Break Saw

\$110/Day \$330/Week \$990/Month

If you are looking for the ideal concrete saw for window and door openings look no further than the Cut-n-Break. This tool has deep cutting of up to 16". Perfect for cutting pipes in pipe trenches, grooves for cabling, expansion joints and crack repair.

Specifications

Engine	
Power Output	5 hp
Cutting Equipment	
Blade Diameter	9 inch
Max Cutting Depth	16 inch
Dimensions	
Weight (excl. cutting equipment)	21.2 lbs
Weight (incl. cutting equipment)	24.5 lbs

Husqvarna K 4000

\$90/Day \$270/Week \$810/Month

Minimizes water and slurry during wet cutting and is easily adapted to dry cutting with the Vac attachment.

Specifications

Engine	
Max Output	2.4hp
Electric Motor	120 volts
Cutting Equipment	
Diamond Blade Max	14"
Max Cutting Depth (w/ Vac unit)	4½"
Max Cutting Depth (w/out Vac unit)	5"
Dimensions	
Product Size (WxH)	8.86"x 16.34"
Weight	17.4lbs
(Including cable; not including cutting equipment or Vac unit)	



Husqvarna K 770 Concrete Saw

\$90/Day \$270/Week \$810/Month

Equipped with a semi-automatic SmartTension™ which allows for optimal power transmission, minimum wear and maximum belt life.

Specifications

Engine	
Max Output	5hp
Cutting Equipment	
Max Diamond Blade	14"
Max Cutting Depth	5"
Dimensions	
Product Size (WxH)	8.86"x 16.34"
Weight	23lbs



Husqvarna 6500 Prime Power Cutter

\$270/Day \$810/Week \$2430/Month

Perfect for indoor cutting, including wet concrete, stone and masonry in buildings as well as pipe cutting in pipe trenches. Its dust suppression system (DEX) maximizes dust reduction and minimizes water consumption.

Specifications

Power	
3-Phase/1-Phase	7.4hp/4hp
Cutting Equipment	
Blade	16"
Max Cutting Depth	6"
Dimensions	
Weight (w/out blade)	22 lbs

Husqvarna K 770 VAC Saw w/ Dust Control

\$105/Day \$315/Week \$945/Month

Lightweight and with all the power and features of the standard K 770, the K 770 VAC has the added benefit of dust extraction, making it the only power cutter of its kind. Ideal for dry cutting.

Engine

Max Output	5hp
Cutting Equipment	
Diamond Blade Max	12"
Max Cutting Depth	5"
Dimensions	
Product Size (WxH)	8.7"x 16.1"
Weight	24.2lbs



Husqvarna PP65 High Frequency Power Pack

This product is included with the Husqvarna 6500 Prime Power Cutter (pictured above). Electric power pack for the 6500 Power Cutter. Easy to carry and use, the PP65 extends your cutting time.

Specifications

Power 3-phase/1-phase	8.7hp/4.7hp
Weight	21 lbs

PLEASE CALL FOR PRICING

Husqvarna DXR 140, DXR 270 & DXR 300 Demolition Robots

Applications:

- Perfect for demolition and smaller excavation work in concrete and brick structures, both indoors and out. It is also suitable for pile-driving, staircases, and roof applications.
- Efficient in tough, dirty environments such as steel and cement processing plants.
- Small design enables work in confined spaces, such as basements.

Benefits:

- Easy to remove side covers to facilitate service and inspection.
- 360° of rotation, based on a hydraulic/electrical swivel technique, allows a more flexible work area.
- Individually controlled outriggers enable it to work on uneven work surfaces or close to walls.
- Low machine profile does not block the line of sight.
- Zero exhaust emissions. 100% electric over hydraulic operation.

Specifications	DXR 140	DXR 270	DXR 300
Reach (forward)	145"	176.4"	192"
Reach (up)	173"	188.4"	204"
Weight	2171 lbs	3858 lbs	4303 lbs
Recommended Generator Size	40kw	50kw	50kw

*Comes with 100ft cord



Grappler

Suitable for demolishing masonry or wooden structures. Can pick up materials to sort and load.



Crusher

Perfect for crushing concrete and brick in buildings, staircases, and roofs where low noise and minimal vibrations are required.



Breaker

Outstanding power to weight ratio and quick and easy to position. Typical applications are road construction, smaller trenching and demolition jobs.



Standard Bucket

Ideal for excavation and debris removal.



Drum Cutter

Made for surface profiling rock or concrete, trenching, excavating frozen soil, soft rock excavation in quarries, demolition and dredging.

CUTTING & DEMOLITION EQUIPMENT

ATTACHMENTS AVAILABLE



Sherpa 100 ECO
\$350/Day \$1050/Week \$3150/Month

Electric mini skid-steer suitable for indoor demolition work. Battery pack that power the unit for up to 7 hours.

Specifications	
Speed	0-4
Voltage	24V
Dimensions	60"L x 30"W
Weight	1,985

Grapple Bucket
\$70/Day \$210/Week \$630/Month

Specifications	
Width	30"
Lifting Capacity	700lbs
Volume	¼ cubic yard



Pallet Forks
\$40/Day \$120/Week \$360/Month

Specifications	
Length	36"
Max Capacity	1,000 lbs



Hydraulic Hammer
\$120/Day \$360/Week \$1080/Month

Specifications	
Tool Diameter	1.77"
Working Weight	200 lbs
Carrier Class	1,500-6000 lbs



Vacuum System
\$120/Day \$360/Week \$1080/Month

Specifications	
Lifting Arm Width	31"
Lifting Capacity	700 lbs
Vacuum Size	8"x12" Pad
Run-Time	5 hours



THE ELECTRIC DUMPER RANGE FROM ECOVOLVE is the world's only fully electric hi-tip dumper. The dumpers are available in three different weight capacities - 1763 lb, 2200 lb and 3300 lb skip. There are no fumes, no emissions, low noise and the steering system significantly reduces the risk of unwanted tire marks. What's more is that the super elastic tires eliminate the possibility of puncture, making the ED Range suitable for both indoors and out.

The electric dumper is perfect for use where operating levels must be low while the compact size and small turning circle means the ED can go where others can't.



Ecovolve ED800
\$225/Day \$675/Week \$2025/Month

Specifications	
Load Capacity (lbs):	1763
Speed (mph):	0-4
Run time (hrs):	8-10
Recharge (hrs):	8
Drive Motor:	5KW/7HP



Ecovolve ED1000
\$250/Day \$750/Week \$2250/Month

Specifications	
Load Capacity (lbs):	2200
Speed (mph):	0-5
Run time (hrs):	8-10
Recharge (hrs):	8
Drive Motor:	5KW/7HP



Ecovolve ED1500
\$275/Day \$825/Week \$2475/Month

Specifications	
Load Capacity (lbs):	3300
Speed (mph):	0-6
Run time (hrs):	8-10
Recharge (hrs):	10
Drive Motor:	8KW/11HP



		ED800	ED1000	ED1500	
CAPACITY	Max safe load (Lbs)	1763	2200	3300	
	Unladen weight (Lbs)	2650	2866	3300	
	Skip	- Leveled (Cubic feet)	12	15	20.3
		- Heaped (Cubic feet)	17	21	28.2
- Water level (Gallons)		60	83	121	
DRIVE	Drive type	1 wheel drive	1 wheel drive	3 wheel drive	
	Steering	1 wheel steer	1 wheel steer	1 wheel steer	
	Speed (Mph)	0-4	0-5	0-6	
	Steering angle	90°	90°	90°	
	Grade ability	15°	15°	15°	
TRANSMISSION	Proportional Steering	Drive Electric	Drive Electric	Drive Electric	
	Tires	27x8,5x15 21x8x9	27x8,5x15 21x8x9	27x8,5x15 21x8x9	
	Brakes	- Front (2no. Super elastic) - Rear (1no. Super elastic)	Dynamic electric brake Negative parking brake		
HYDRAULIC SYSTEM	Gear pump	- Flow rate (Gallon/Min) 1.45	1.45	1.72	
	Pump motor (KW)	- Oper. pressure (PSI) 1900	1900	2100	
	Hydraulic tank capacity (Gallons)	2.2	2.2	2.2	
ELECTRIC SYSTEM	Voltage (V)	24	24	24	
	Battery (Ah)	400	400	600	
	Integrated Charging	- Input (V AC)	100-240	100-240	100-240
		- Output (V DC)	24	24	24
Recharge (Hrs)	8	8	10		
DRIVE MOTOR	Type		Induction Motor		
	Output	5KW/7HP	5KW/7HP	8KW/11HP	
	Emission	Zero	Zero	Zero	
NOISE	Driving (Db)	65	65	65	
	Buzzer [adjustable] (Db)	60-80	60-80	60-80	

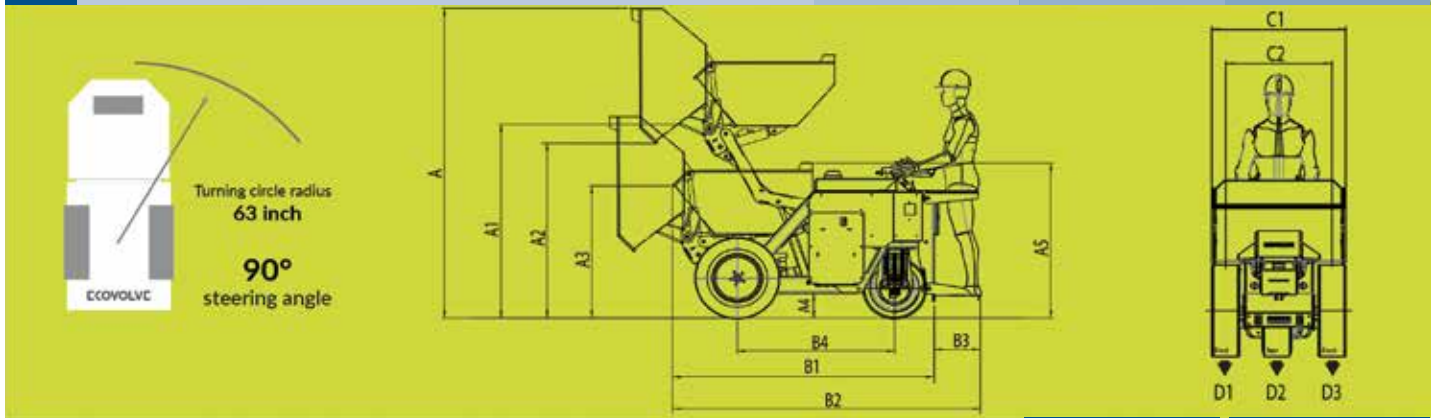

(in)													UNLADEN		LADEN	
	A	A1	A2	A3	A4	A5	B1	B2	B3	B4	C1	C2	D1/D3	D2	D1/D3	D2
ED800	103	64	58	44	8.3	51.5	81.3	94	13.0	50	32	23	617 lbs	1500 lbs	1433 lbs	1543 lbs
ED1000	103	64	58	44	8.3	51.5	86.6	101	13.0	50	38	30	683 lbs	1500 lbs	1730 lbs	1609 lbs
ED1500	114	71	63	45	8.3	53	88.4	101.4	13.0	52.2	46.2	38.4	827 lbs	1653 lbs	2480 lbs	1653 lbs

GROUND PRESSURE

CUTTING & DEMOLITION EQUIPMENT



Husqvarna Soff-Cut Prowler 150 Saw

\$105/Day \$315/Week \$945/Month

The Husqvarna Soff-Cut 150 saw is designed for same day residential and light commercial applications. The lightest gas saw in the Soff-Cut range, the 150 is designed for ease of use and convenience.

Specifications

Engine

Motor manufacturer	Subaru
Motor spec	EX13
Max output	3.2 kW / 4.3 hp (As rated by the engine manufacturer)
Fuel tank volume	0.7 gal.
Starter	Recoil
Engine cooling	Air

Cutting Equipment

Output RPM	3800 rpm
Diamond blade, max	6"
Max cutting depth	1.18 inch
Blade depth control	Manual
Blade control	Manual
Weight	87 lbs (91 lbs w/packaging)



Husqvarna 1000 Soff Vac

\$185/Day \$555/Week \$1665/Month

The Husqvarna Soff-Cut 1000 Soff-Vac is the latest innovation in jobsite collection systems. Unlike other systems, which require frequent maintenance and multiple trips to clean up areas, the 1000 Soff-Vac is the easiest to use system, which delivers the smoothest, non-scratching, dust-free finish available today.

Specifications

Power	11hp (8kW)
Engine	Gasoline
Air flow (CFM)	300
Pressure water life, (in)	93
Inlet	3"
Weight	513 lbs

*Compatible with all soff-cut saws

Husqvarna Soff-Cut 2000 Saw

\$285/Day \$855/Week \$2565/Month

The Husqvarna Soff-Cut 2000 self-propelled dry cutting gas saw has a low noise enclosed design and is ideal for medium to heavy-duty commercial, industrial and paving applications, in pipe trenches, grooves for cabling, expansion joints, and crack repair.

Specifications

Engine

Motor manufacturer	Honda
Motor spec	GX390
Max output	11 hp
Fuel tank	1.6 gal.
Starter	Electric

Cutting Equipment

Output RPM	3200 rpm
Diamond blade, max	10"
Max cutting depth	1.5 inch
Blade depth control	Electric
Weight	347 lbs



20

Husqvarna Soff-Cut 4000 Saw

\$350/Day \$1050/Week \$3150/Month

The Husqvarna Soff-Cut 4000 self-propelled gasoline saw is designed for heavy-duty commercial, industrial, and paving applications. Features include a 20 hp twin-cylinder engine with overhead valves, heavy-duty air cleaner, electric start, full pressure lubrication, hydraulic valve lifters and a mechanical fuel pump. Three blade widths can be used, allowing different joint widths and crack control simultaneously.

Specifications

Engine

Motor manufacturer	Kohler
Max output	15.3 kW / 20.5 hp
Starter	Electric
Engine cooling	Air

Cutting Equipment

Diamond blade, max	13.5"
Max cutting depth	2.75 inch
Blade depth control	Electric
Blade control	Electric Remote
Weight	420 lb



Husqvarna Soff-Cut 4200

\$390/Day \$1170/Week \$3510/Month

Self-propelled dry-cutting gasoline saw has a low-noise enclosed design and is ideal for heavy-duty commercial, industrial and paving applications.

Specifications

Engine

Motor	Kohler CH680
Horsepower	22
RPM	3,500

Cutting Equipment

Blade Range	10" - 13 1/2"
Cutting Depth	1-1/8" - 3"
Weight	488 lbs

Note: Blade included



Husqvarna FS7000 D 36" Diesel Saw
 \$350/Day \$1050/Week \$3150/Month

Our most powerful diesel walk-behind floor saw with low emissions, developed to be compliant with Tier 4 regulations. Ideal for asphalt and concrete cutting up to 15" deep.

Specifications	
Engine	
Motor manufacturer	Deutz
Max output	74 hp
Cutting Equipment	
Diamond Blade Max	36"
Max Cutting Depth	15"
Weight	2136 lbs



Husqvarna FS3500 Saw Gas or Electric
 \$275/Day \$825/Week \$2475/Month

The Husqvarna FS3500 features a well-balanced, low profile design. Ideal for repair and removal of driveways and sidewalks.

Specifications	Gas	Electric
Engine		
Motor manufacturer	Kohler	Lincoln
Horsepower	37hp	30hp
RPM	1860	1600
Cutting Equipment		
Diamond Blade Max	30"	30"
Max Cutting Depth	12-3/8"	12"
Weight	970 lbs	1486 lbs



Husqvarna FS400 18" Saw
 \$150/Day \$450/Week \$1350/Month

Specifications	
Engine	
Honda GX390	
Power Output	11 (8) hp
Cutting Equipment	
Diamond Blade Max	18"
Max Cutting Depth	6-5/8"
Other	
Weight	219 lbs
Water Tank Capacity	7.9 gal



Gorilla 10" Electric Walk Behind Saw
 \$105/Day \$315/Week \$945/Month

A heavy duty electric concrete saw that is great for new construction, demolition work and joint clean out. Also a great solution for jobsite dust control. Eliminates dust when cutting concrete.

Specifications	
Blade Size	8-10"
Max Cutting Depth	3.25"
Power Requirements	15A-120v
Grinder Model	Metabo W24-230
Weight	60 lbs

7" - 9" Spider Walk Behind Concrete Saw
 \$85/Day \$255/Week \$765/Month

Concrete saw designed through years of concrete experience and manufactured for endurance.

Specifications	
Motor	Honda GX200 6.5 HP
Blade size	7" - 9"
Max Cutting Depth	2.5"
Arbor size	5/8"
Weight	104 lbs
Switches	Dual Levers with safety lock
Wheels	Two 5" wheels with non-marking tread
Dimensions: (L x W x H)	24.5" X 21" X 47"



PUMPS/SPRAYERS



Chemgrout Trailer Mounted Pump & Mixer

\$525/Day \$1575/Week \$4725/Month

This workhorse unit is designed to mix and pump a variety of products, including neat cement, bentonite, self-levelers and most packaged grout mixes. The trailer is road- and job site-ready with leaf springs, lights, and a working platform.

Specifications

Mixing Tank	45 gal
Holding Hopper	12 gal
Max Output	8 GPM
Max Pressure	174 PSI
Engine	13 HP Honda Diesel
Dimensions (LxWxH)	110"x 68"x 73"
Weight	1550 lbs
Hose Length	Up to 150' (2-50' & 2-25')

**Smaller compressor required for spray applications*



Graco S340E Electric Powered Pump/Sprayer

\$375/Day \$1125/Week \$3375/Month

Engineered with piston pump technology, ToughTek Pumps deliver high pressures to move materials through long hose lengths. Graco's piston pump technology easily handles low, medium and high-density materials, delivering them with a smooth, steady flow rate.

Specifications

Weight	150 lbs
--------	---------

**Includes 1.5"x30" hose*



Graco 833 Gas Powered Big Rig Sprayer

\$325/Day \$975/Week \$2925/Month

The GH 833 is the preferred choice for high production professional contractors who spray a wide range of materials. Gas hydraulic unit that can spray it all including asphalt emulsions, waterproofing, elastomeric acrylics and mastics - 4.0 GPM, 4000 PSI. 3/8" x 50' airless hose, 1/4 in x 3ft whip hose.

Specifications

Weight	150 lbs
--------	---------



QuikSpray Carousel Pump Electric or Air

\$375/Day \$1125/Week \$3375/Month

Pump and spray a variety of commercial products - epoxy grout, cement or plaster - with or without aggregate. Phipps can provide recommended products from our large database of products we have tested with the QuikSpray pump. Pneumatic or electric power available.

Specifications

Air Power Requirement	125 CFM compressor
Electric Power	110V/15amp
Hose Length	20'



QuikSpray Mixer

\$125/Day \$375/Week \$1125/Month

The U-Blend Mixer is specifically designed to allow lower dumping heights for a variety of containers that eases operator fatigue.

Specifications

Volume	4+ cu/ft working capacity
Height	46" max - 27.5" min
Power Source	Air or Electric Available



Graco 7900 Gas-Powered Sprayer

\$105/Day \$315/Week \$945/Month

The GMAX II 7900 sprayer is the most powerful sprayer for high production paint contractors doing large tract, commercial and new residential construction jobs where uninterrupted spraying is expected. Can Spray all paints, acrylics, polyester and cold tar 2.2 GPM 3300PSI. 3/8" x 50' airless hose, 1/4 in x 3ft whip hose.

Specifications

Weight	185 lbs
--------	---------



Kenrich Air Operated Pump
 \$80/Day \$240/Week \$720/Month

Air operated, easy to operate, minimal maintenance required. Pumps most types of cementitious grout (not for epoxy-type grouts). 10 CFM compressor recommended - comes with 7' of hose. 5 gallons/min output.

Specifications	
Weight	20 lbs



Seal-Boss 1:1 Injection Pump
 \$60/Day \$180/Week \$540/Month

This extremely lightweight and powerful injection pump can be used for most polyurethane and epoxy injection products with viscosities between 10 and 1000 cps.

Specifications	
Weight	10 lbs



Ultra_Trak 36" Pressurized Application System
 \$110/Day \$330/Week \$990/Month

- Apply floor finishes or sealers at 25,000 sq/ft hour (10x faster than conventional application methods)
- Environmentally responsible: Cut product waste by up to 20%
- Fully automatic & pressurized
- Fully adjustable application feature
- Built-in charger with a battery run time of 5 - 7 hours

*Rental does not include 36" microfiber applicator pad



Seal Boss Dual Component Polyurea Pump
 \$345/Day \$1035/Week \$3105/Month

Rugged and lightweight construction make this machine a prime choice. The powerful electric motor will keep up even with the fastest operator. For use with non-filled epoxy and polyurea with a 1:1 ratio.

Specifications	
Weight	150 lbs



Seal-Boss 2:1 Injection Pump
 \$80/Day \$240/Week \$720/Month

This lightweight and powerful injection pump can be used for dual component epoxy and/or polyurethane injection resin with viscosities between 10 and 1000 cps.

Specifications	
Weight	15 lbs



Bartell S201 Power Sprayer
 \$95/Day \$285/Week \$855/Month

Sprays materials with a variable pressure between 40 and 120 psi while constantly agitating material. Easily handles form oils, pigmented curing compounds, bond breakers, soaps and detergents, pest control liquids, and most liquid type material. Handles pigmented material up to 40% solids. 3/8" x 50' hose.

Specifications	
Engine	Honda GX120
Power	5.5 HP
Weight	110 Lbs
Hose length	50'
Pressure	40 - 120 PSI



4000 PSI Pressure Washer
 \$70/Day \$210/Week \$630/Month

The industrial-grade Honda GX390 389cc OHV engine features a cast iron sleeve, and a horizontal shaft design for up to five times longer life than vertical shaft engines. A premium-quality Cat direct drive axial pump with ceramic plungers and a forged brass manifold provide superior performance and durability. Comes with 50' of hose.

Specifications	
Weight	191.0 lbs
Pressure (PSI)	4,000
Flow (GPM)	3.5
Engine	Honda
Engine Model	GX390





CLIMATE CONTROL EQUIPMENT ACCELERATE THE OUTCOME OF PROJECTS

Air Movers

Dehumidifiers

HEPA Air Scrubbers

Portable Electric Heaters

Ground Thaw Systems

Hydronic Heaters

Air Conditioning

Portable Climate Control Equipment

We offer a complete line of rugged, high performing, climate control equipment designed and engineered for the construction, concrete and painting professional.

Offering years of expertise in dehumidification, drying and heat. We provide a premium line of portable climate control equipment to the construction industry including refrigerant dehumidifiers, portable and large desiccant dehumidifiers, air movers, HEPA air scrubbers, electric spot heating and spot cooling. And, with the addition of its revolutionary customized modular hydronic heating systems, we now have the perfect solution for ground thaw, concrete curing, frost prevention, temporary and emergency heat applications as well.

Climate Control Equipment Provides:

- Durable, high performing, energy efficient equipment made in the USA
- Years of expertise on correct equipment choice and set-up for any construction application



Hydronic Heating: Providing the Perfect Climate for Construction

How does Hydronic Heating work in Construction?

Heated food-grade glycol is pumped through a hose to thermostatically controlled heat exchangers inside the workspace. The hot glycol passes through fan coils and blows warm air throughout the work area. The heat exchangers are continuously circulating the warm air for maximum effectiveness. When the glycol does not need to be heated, the burner which is outside of the building, goes into standby mode which results in maximum efficiency and fuel savings.

Features:

- Production Schedule Control
- Fume Free Work Areas
- Dry/Even Heat Distribution
- Quiet Operation
- Tremendous Fuel Savings

Benefits:

- Avoid delays by maintaining jobsite temperature and humidity levels
- No harmful CO or CO₂s introduced into work environment.
Can be used as part of a LEED or ICRA program
- Moisture is removed from the air instead of introduced
- No OSHA noise concerns inside or outside
- Operating costs are typically 1/3 to 1/6 of traditional open flame heating methods

Contact our Climate Control Specialist to evaluate your project heating specifications and provide a solution for a Hydronic Heating System.

Heath Warner: 419-466-3244 or hwarner@chasehipps.com



Powerheat 4500 Trailer

The PowerHeat 4500 is more than just a ground thaw unit, it can also serve as building heat and emergency heat when used with hydronic exchangers.

Specifications

Fuel	
Efficiency:	80%
Fuel Tank Capacity:	230 gal
Run Time @ Full Load:	85 hrs
Operating Temperature Range:	
	-30°F - 140°F
Dimensions:	
Weight:	7900 lbs
Weight w/ Full Fuel Tank:	9500 lbs
Product Size:	176"x 93"x 97¼"



Quest Power Air Mover A3000 Plus

\$20/Day \$60/Week \$180/Month

The Quest Power Air Mover A3000 Plus has changed the drying industry by minimizing overall drying time on restoration jobs. By maximizing the air velocity, water evaporates more quickly from the carpet, pad, sub-floor, wall, and sill plate.



Quest PowerDry 4000 Pro

\$85/Day \$255/Week \$765/Month

The 4000 Pro is a larger capacity, stainless steel unit designed with the combination of high performance and portability. The multiple ducting options on the 4000 Pro allows for ducting both the intake and processed air, and easily combines this unit with a HEPA air scrubber.

- Weight - 85 lbs



Husqvarna A 1200 Air Scrubber

\$75/Day \$225/Week \$675/Month

Portable air cleaners available on the market. A reliable filter system and a design that is perfectly matched to operation with HEPA class H13 filters, that are tested and certified at an efficiency rate of 99.99% at 0.3 microns, the air cleaner puts out superior air quality - be it when dealing with concrete dust, fine sanding dust or gypsum dust.

Specifications:

A1200	
Power	.60 KW
Max Rated Current	4.9 A
Power Supply	1-phase
Airflow	600/1200 CFM
Weight	150 lbs

*All Filters and Hoses Are Sold Separately

A1200	
Pre-Filter 24" x 24" x 1"	\$7.50
HEPA Filter 24" x 24"	\$295.00
PowerDry 4000	
4000 Pro-Filter Merv 11	\$9.50
4000 Pro-Filter Merv 8	\$6.50
Hose	
Flex Duct - 12" x 25'	\$65.00
Lay Flat Duct - 10" x 250'	\$42.00



Portable A/C Units

	KwiKool KIB1411	KwiKool KPO5-21
Pricing	\$95/Day \$285/Week \$855 Month	\$190/Day \$570/Week \$710/Month
Cooling Capacity	13,800 BTU/hr (1.1 Ton)	60,000 BTU/hr (5 Ton)
Minimum Circuit Amp/Voltage	19.575 amp / 105-125 V	37.5 amps / 208-230 Single Phase
Operating Range	60-110 degrees	65-110 degrees
Max Duct Length	25'	65'
Weight	195 lbs	670 lbs
Size (LxWxH)	16"x36"x37"	32"x48"x49"

BLASTING EQUIPMENT



Graco Eco-Quip 400T

\$950/Day \$2850/Week \$8550/Month

The Graco EcoQuip 2 EQ400t vapor blast machine is designed for the toughest high production projects and comes with a Tier 3 compressor with 375 CFM @ 125 PSI. Comes with 50' of blast hose.

Specifications:

Maximum Working Pressure	125 psi
Operating Temperature	35° - 110° F
Air Compressor	375 CFM
Blast Hose Size	1.25 in. ID
Abrasive Capacity	880 lb
Dry Weight	6000 lb
Water Tank Volume	130 gallon



Graco Eco-Quip EQS

\$650/Day \$1950/Week \$5850/Month

Built to withstand the toughest working conditions, the Eco-Quip EQS is a high-production standalone unit to tackle your largest, most demanding projects. Comes with 50' of blast hose & 50' of air hose.

Specifications:

Maximum Working Pressure	125 psi
Operating Temperature	35° - 110° F
Air Compressor	375 - 600 cfm
Blast Hose Size	1.25 in. ID
Abrasive Capacity	400 - 500 lb
Dry Weight	1100 lb
Water Tank Volume	115 gallon
300-600 cfm compressor and less than 100 ft hose length 1.5 in.	



Graco Eco-Quip EQM

\$425/Day \$1275/Week \$3825/Month

With its built-in hand truck, slide rails and convenient lifting eye, the patented Eco-Quip EQM design is easy to move at the jobsite. The Eco-Quip EQM can accommodate any abrasive heavier than water. Capable of handling any type of project, from cleaning to surface preparation. Comes with 50' of blast hose & 50' of air hose.

Specifications:

Maximum Working Pressure	125 psi
Operating Temperature	35° - 110° F
Air Compressor	185 - 375 cfm
Blast Hose Size	1 in. ID
Abrasive Capacity	100 - 250 lb
Dry Weight	360 lb
Water Tank Volume	10 gallon
185-600 cfm compressor and less than 100 ft hose length 1.5 in. ID	

About Vapor Abrasive Blasting

- Generates less dust - 92% less airborne dust than dry blasting
- Optimizes air, water and media ratio - resulting in a fine mist with a blast that is powerful, but with less dust
- Uses less water than traditional water-based wet blasting
- Uses less media than wet blasting, so clean up is minimal and you save on media costs

50' Blast Hose Extension \$40/day \$120/week \$360/month

50' Air Hose Extension \$30/day \$90/week \$270/month

Crushed Glass Media \$9.25 (50LB bag)
for blasting concrete/masonry or when a light blast is required.

Garnet Blast Media \$17.80 (55LB bag)
for blasting steel or when an aggressive blast is required.

MISCELLANEOUS



Arbortech Brick and Mortar Saw
\$90/Day \$270/Week \$810/Month

The AS170 Brick + Mortar Saw represents a revolution in cutting technology. Using a unique patented orbital cutting motion with two forward facing blades that combine to perform both a hammering and cutting action. Blade not included.



Husqvarna Hand Held Core Drill
\$50/Day \$150/Week \$450/Month

The Husqvarna Handheld Core Drill is a core drill for drilling up to 4in. diameter openings. The unit can be used for a variety of applications including making holes for ventilation, plumbing pipes, joints, electrical sockets and telecom cables. For use with DR15 and hand-held core bits. Core bits are not included.



Fein MultiMaster Tool
\$45/Day \$135/Week \$405/Month

FEIN SuperCut is the right power tool for all professionals in the interior and renovation trades. With a 400 Watt motor and stronger oscillation movement, the FEIN Supercut means maximum progress, resulting in time and cost savings. Blade not included.



5" Grinder with Tuckpointing Shroud
\$40/Day \$120/Week \$360/Month

Robust tuck pointing system with dust extraction for quick removal of mortar joints.



Spectra HV101 Laser Kit
\$70/Day \$210/Week \$630/Month

Multipurpose construction laser for interior and exterior applications. Exceptional versatility allows it to handle a wide variety of horizontal, vertical and plumb applications. The HV101 laser transmitter is automatically self leveled in the horizontal and vertical planes and sends a continuous 360-degree laser reference over the entire work area. The HV101 laser is easy to set up and use and is rugged enough for the toughest jobsite.



MAX Tool Rebar TwinTier RB441T
\$85/Day \$255/Week \$765/Month

The RB441T "TwinTier" is a 6th generation MAX Re-Bar-Tier. It features 3 new innovative mechanisms making it the most efficient rebar tying tool on the market. Wire sold separately.

Specifications

Weight	5.6 lbs
Minimum Ties Per Coil	145
Maximum Ties Per Coil	265
Applicable Rebar Size	# 3x #3 - #7 x #7
Ties Per Charge	4000
Tie Speed	Approx. 1/2 sec
Tie Wraps	2
Battery Charge Time	40 minutes full charge



32" Concrete Cleaner
 \$45/Day \$135/Week \$405/Month

Clean large surfaces faster and easier than with a standard cleaning nozzle. This cleaning accessory can be used on decks, patios, sidewalks, driveways, pool decks, parking lots and any other horizontal surface. Requires a 4000psi pressure washer and can use heated water up to 200°F.

Specifications

Weight	120 lbs
--------	---------



Generac 17KW Generator
 \$95/Day \$285/Week \$855/Month

The most powerful portable generator on the market and can provide power for up to 16 circuits.

Specifications

AC Rated Output Running Watts	17500
AC Maximum Output Motor Starting Watts	26250
AC Voltage	120/240 VAC
AC Frequency	60 Hz
Rated VAC Amperage	145.8 / 72.9
Max Rated VAC Amperage	218.75 / 109.38
Engine Displacement	992cc
Weight	250 lbs



Bartell 5000W Generator
 \$75/Day \$225/Week \$675/Month

Specifications

Rated Output (W)	4500
Max Output (W)	5000
Rated Current (A)	18.8
Voltage	120/240
DC Output (V)	12
Weight	172 lbs



Generac MMG75D Generator
 \$300 daily/\$900 weekly/\$2700 monthly

Specifications

John Deere® PE4045HFG92	Turbocharged, diesel engine
Prime	97 hp @ 1800 rpm
Standby	107 hp @ 1800 rpm
Cylinder	4
Displacement	4.5 L
Interim Tier IV Approved	
Steel, single wall fuel tank	
Capacity	165 gal.
Run time - full load	31 hr.
Fuel tank built into skid of set	
Fuel consumption at prime	100% - 4.78 gph 75% - 3.74 gph 50% - 2.6 gph
Cooling System	120°F ambient
System Outputs	3 position selector switch
Single Phase Zig Zag	120 / 240V
Three Phase Low Wye	120 / 208V
Three Phase High Wye	277 / 480V
Standby, Single Phase	60 kW / 60 kVA
Prime, Single Phase	56 kW / 56 kVA
Standby, Three Phase	69 kW / 86 kVA
Prime, Three Phase	62 kW / 77 kVA
Weight (Dry)	3530 lbs (skid mounted) 4240 lbs (trailer mounted)

MISCELLANEOUS



Allen Steel Pans

Allen Engineering pioneered the use of pans on riding trowels in 1989 and Allen Pans remain today the finishers choice when high Ff numbers are specified on a concrete floor.



Soff Cut Early Entry Blades

Soff-Cut blades provide highly efficient, stable and convenient operation in traprock, chert, quartz and limestone concrete. An anti-ravel skid plate comes with every blade. This allows for same-day sawing without chipping and spalling.

Husqvarna Diamond Cup Wheels

Sizes range from 4" to 7". Available in single row, double row, turbo segments and arrow design segments. PCD's for the removal of glue, epoxy and vinyl.





1.



2.



3.



4.



5.

1. Husqvarna HI Series Diamond Blade

HI series is the only all-purpose blade with notched segments which grab and grind material. Available in 12", 14" and 16".

2. Vari-Cut 14" Blade

General purpose blade made to cut cured concrete and brick. A broad range of applications make the Vari-Cut a great combination blade.

3. Husqvarna VH Series Diamond Blade

General purpose cutting of cured concrete and brick. Segment height .400". Available in 12" and 14".

4. Husqvarna FR3 Fire Rescue Blade

For metal, concrete, brick/block. Recommended when free cutting of any material is critical.

5. Husqvarna Professional F600C Series

For cured concrete cutting 20-72 HP. Narrow notch design, 24" or larger have recessed segment undercut protection.

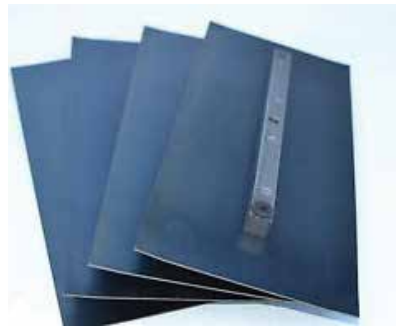

Finish Blades • Combo Blades • Clip-On Float Blades

Complete line of finish blades, combination blades and clip-on float shoes for your walk-behind or ride-on power trowels. High quality steel or composite plastic with high strength rivets to maximize blade life.



Vision: Customers and suppliers will consider Phipps to be a first choice distributor of high quality and innovative construction products and equipment. Phipps also will provide employees with the opportunity to have a fulfilling work experience.

Mission: Phipps helps contractors put work in place correctly and profitably by supplying high quality and innovative products and equipment, technical expertise, and trusted service.

Customers Served

- General contractors
- Renovations
- Concrete
- Masonry
- Other sub-trades

Markets Served

- Infrastructure
- Manufacturing
- Industrial
- Commercial
- Institutional

Chas. E. Phipps Equipment Service: Joe Harris heads up our Equipment & Service program. He brings to Phipps 30+ years of experience in equipment service, sales and rental. Joe is a certified technician for Honda, Kohler, Briggs & Stratton and Kubota engine repair. He's completed training on concrete repair and cleaning equipment for; Allen Engineering, Advance, Tennant, Blastrac, Karcher, SPE, Graco Sprayers, Multiquip, Husqvarna and Edco.



Online Solutions
chasehipps.com
or Call: (216) 641-2150



Cleveland:
Main Office & Warehouse
4560 Willow Parkway
Cleveland, OH 44125
1-800-362-9267

Canton:
Branch Office & Warehouse
2993 Perry Drive SW
Canton, OH 44706
1-877-258-7601

Toledo:
Branch Office & Warehouse
12450 Williams Road
Perrysburg, OH 43551
1-800-860-3352

Updated June 2020

